

El incumplimiento de estas instrucciones exime de toda responsabilidad a TRES Grifería. TRES Grifería décline toute responsabilité en cas d'insobserance de ces instructions. Bei Nichtbefolgung der Bedienungsanleitung übernimmt TRES Grifería keinerlei Haftung. Het niet opvolgen van deze instructies ontslaat TRES Grifería van alle aansprakelijkheid. L'inadempiemento di queste istruzioni esonera TRES Grifería da ogni responsabilità. Nedodržení pokynů v návodu zbavuje společnost TRES Grifería veškeré zodpovědnosti. Any failure to follow these instructions releases TRES Grifería from any liability. Niezastosowanie się do instrukcji zwalnia z wszelkiej odpowiedzialności TRES Grifería.

TRES

VALORES DE CONEXIÓN • VALEURS DE BRANCHEMENT • ANSCHLUSSWERTE • WAARDEN VAN DE VERBINDING VALORI DI CONNESSIONE • NASTAVENÍ PŘIPOJENÍ • FITTING CONNECTION SPECIFICATIONS CHARAKTERYSTYKI PODŁĄCZENIA • CONDIÇÕES DE CONEXÃO • ПРОМЫВКА СИСТЕМЫ

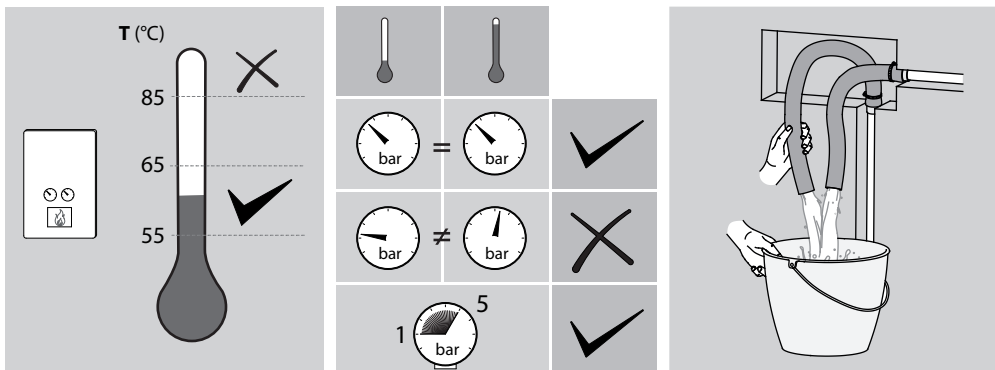

No realizar pruebas de presión ni estanqueidad de la instalación con la grifería instalada. / Ne pas réaliser d'essais sous pression ni d'essais d'étanchéité sur l'installation une fois la robinetterie montée. / Führen Sie bei installierter Armatur keine Drucktests oder Dichtheitsprüfungen an der Anlage durch. / Test de druk of de waterdichtheid van de installatie niet als de kranen zijn geïnstalleerd. / Non eseguire prove di pressione o di tenuta stagna dell'impianto con la rubinetteria installata. / Neprovádějte tlakové zkoušky a testy vodotěsnosti zařízení s nainstalovanou baterií. / Neither pressure nor watertightness tests can be carried out on the installation with the faucets installed. / Nie wykonywać prób ciśnieniowych ani szczelności w instalacji z zamontowaną baterią. / Não realizar testes de pressão nem de estanquidade da instalação com as torneiras instaladas. / Не проводить испытание давления и водонепроницаемости оборудования с установленными смесителями.

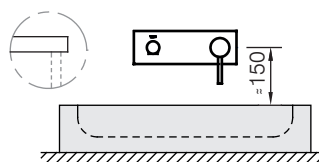
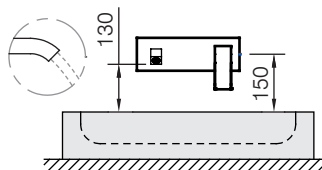
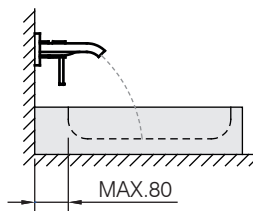
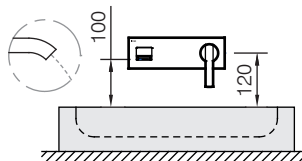
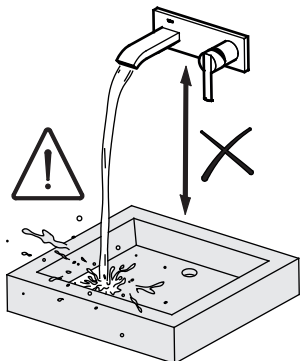

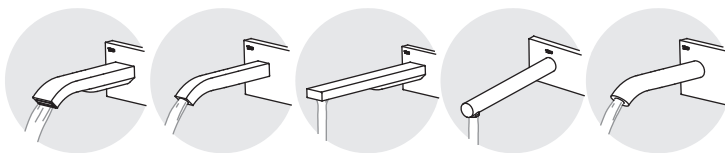

1

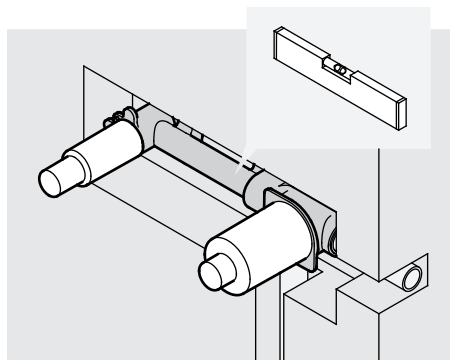
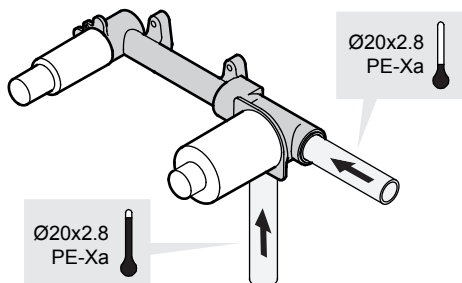

2

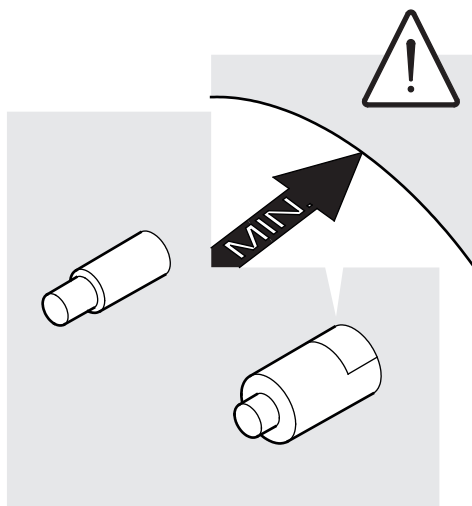
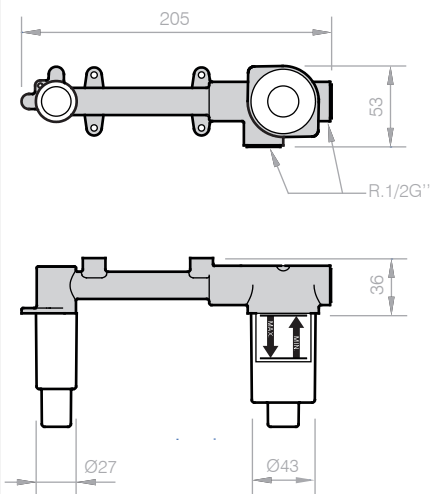

3

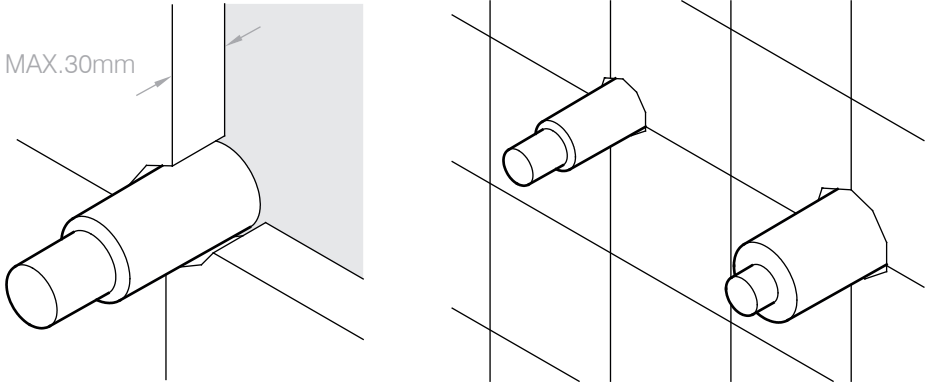

4

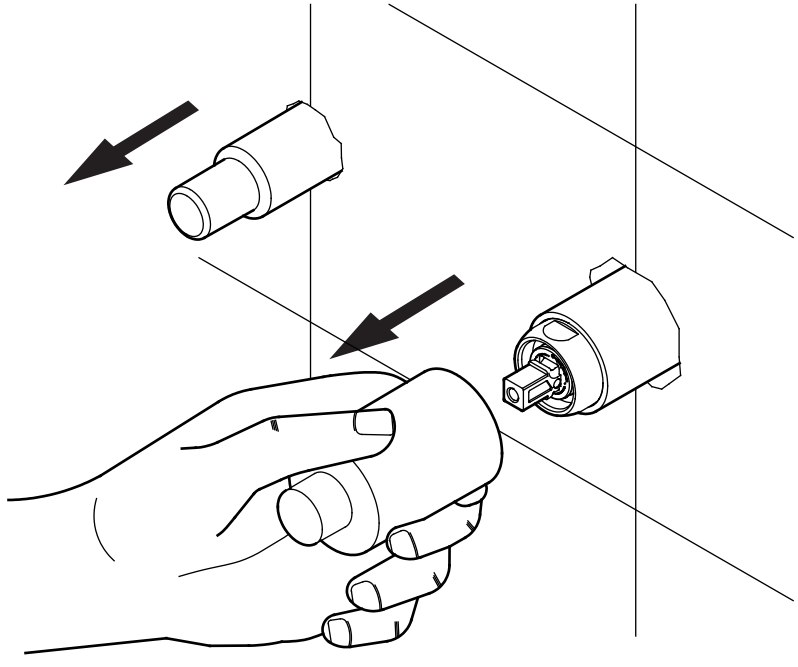

5

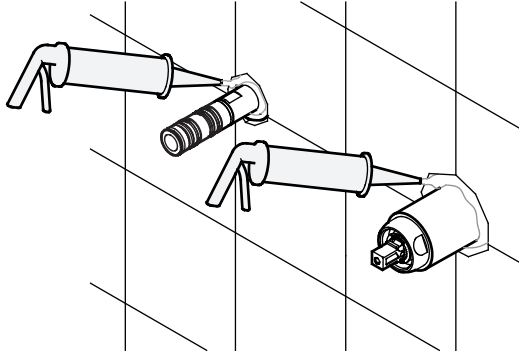

6

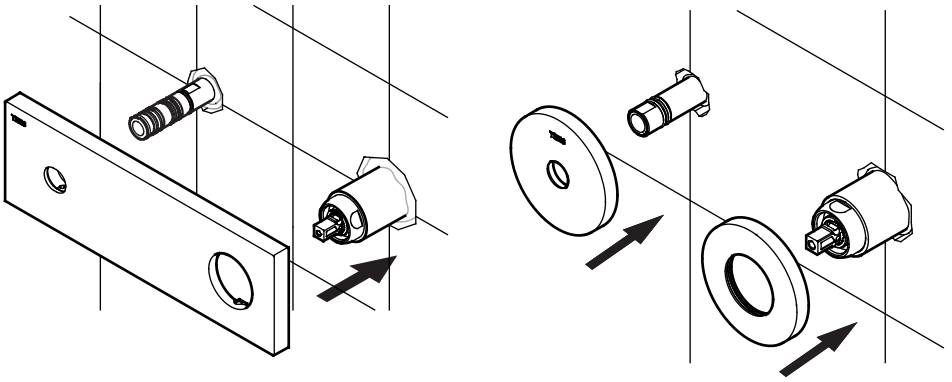

7

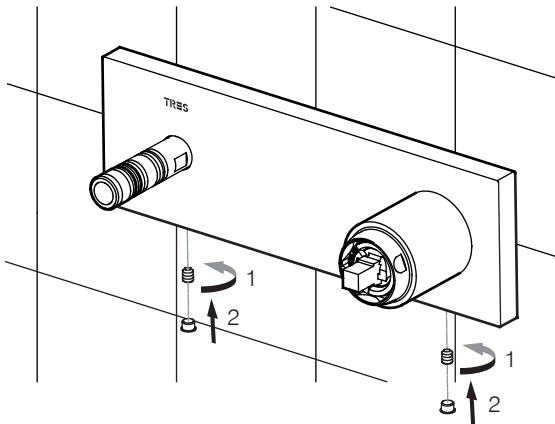

8

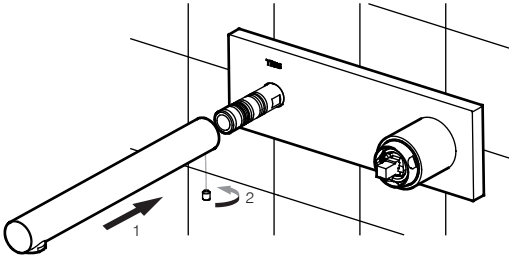

9

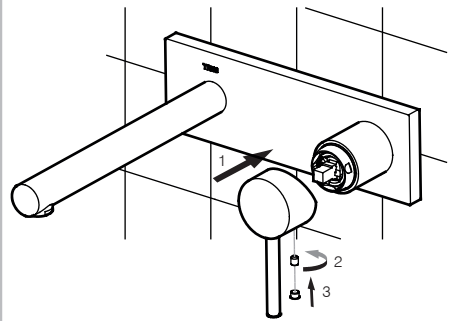

MANTENIMIENTO • ENTRETIEN • WARTUNG • ONDERHOUD • MANUTENZIONE • ÚDRŽBA
 MAINTENANCE • KONSERWACJA • MANUTENÇÃO • ТЕХНИЧЕСКАЯ ПОДДЕРЖКА

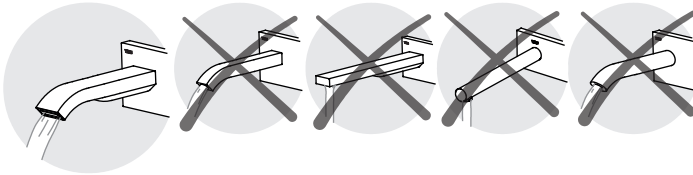

1

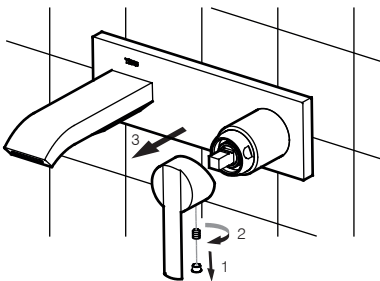

2

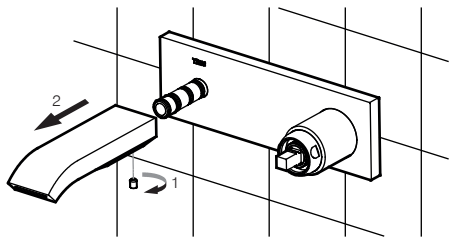

3

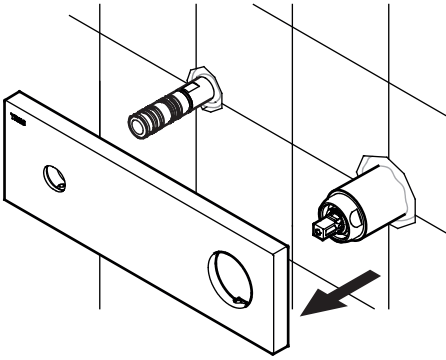

4

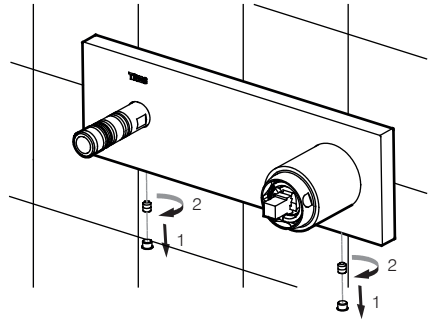

5

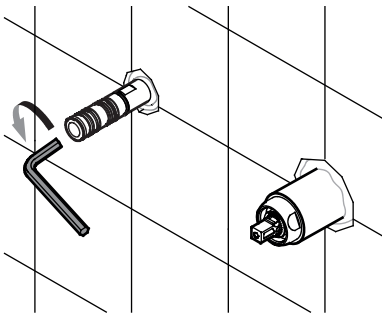

6

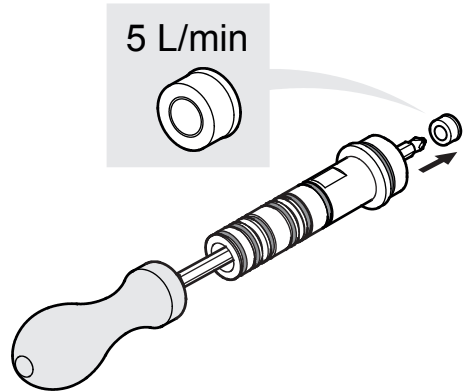

7

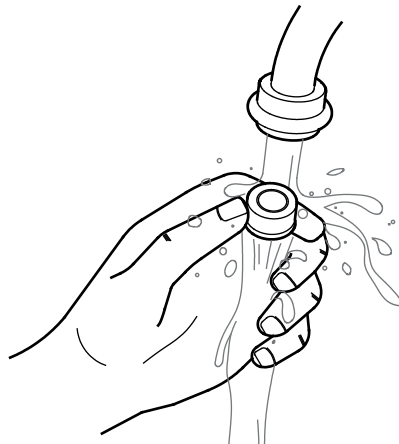

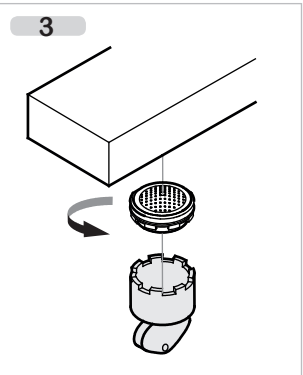
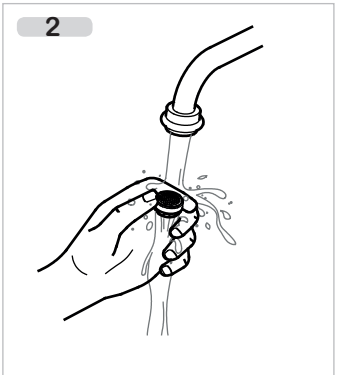
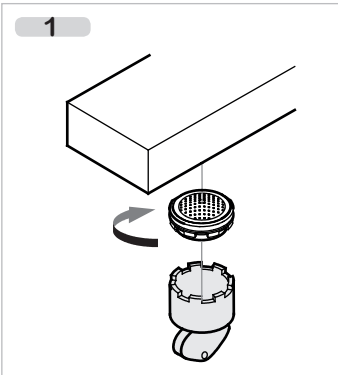
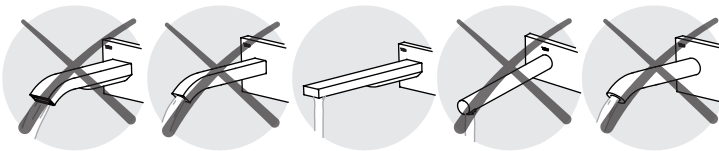
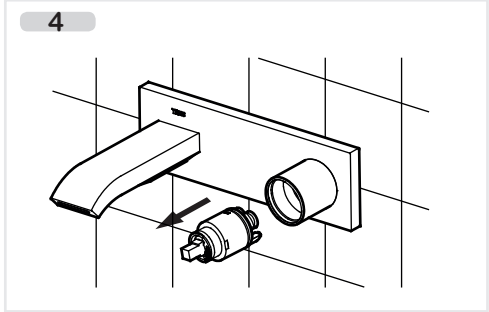
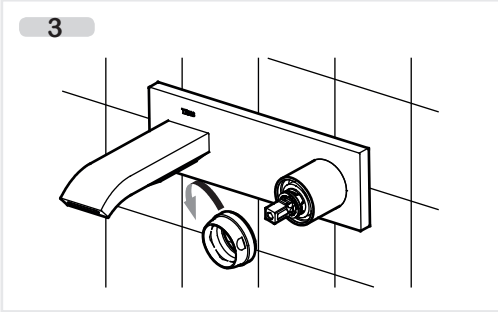
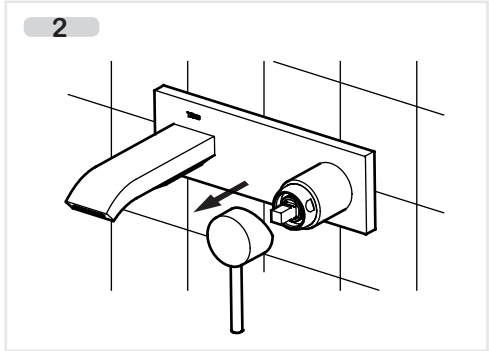
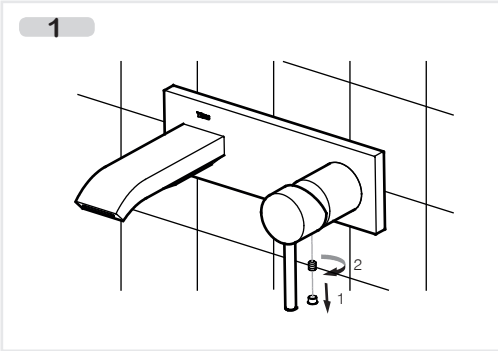
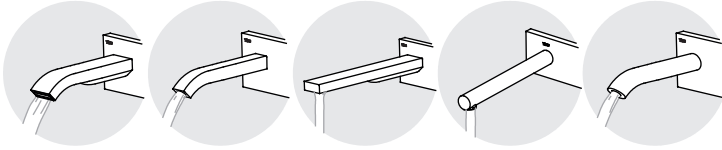

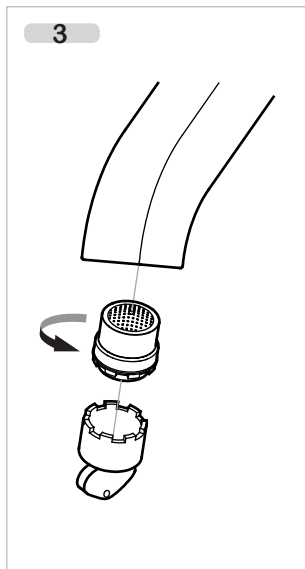
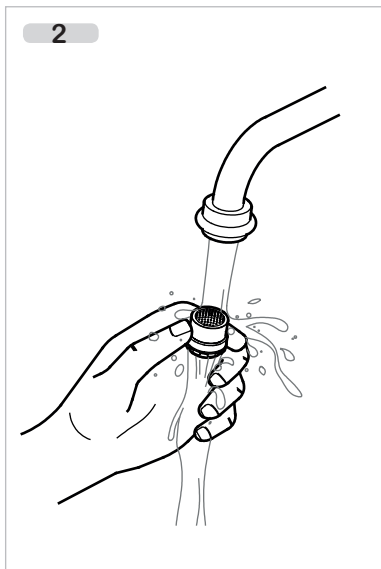
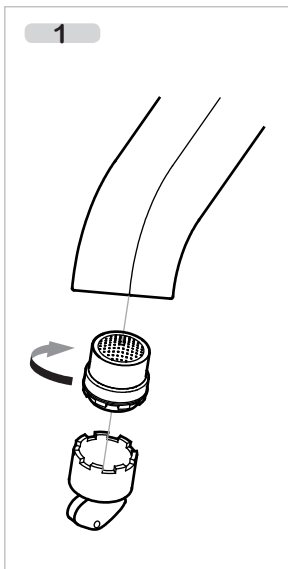
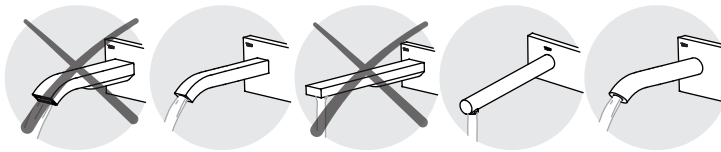

LIMPIEZA • NETTOYAGE • REINIGUNG • REINIGING • PULIZIA • ČIŠTĚNÍ
CLEANING • CZYSZCZENIE • LIMPEZA • ЧИСТКА

